

ACTUATOR SERIES 90 PROPORTIONAL

ESBE actuator Series 90 for operating ESBE mixing valves DN 15–150. This series is provided with adjustable cam discs to obtain an operating range 30°–355° which make the series very flexible.

OPERATION

The ESBE series 90 actuator is a compact actuator for operating rotary mixing valves. The actuator is reversible and is provided with limit switches which are actuated by cam discs. For 1255 01 00 to 1255 03 00 the operating range is 90° alt. 180°, and for 1255 04 00 the operating range is 355°. The actuator is provided with a disconnection for manual operation and has an indication on the front showing valve position.

The actuator is also available in step motor driven versions for regulation with different proportional signals and running times. Supply voltage 24V AC/DC. The actuators are factory set at 0–10 V and 15 s for 1255 03 00, 60 s for 1255 01 00 resp. 120 s for 1255 02 00. Any adjustments are made by removal of front cover.



1 To operate the valve manually, push the button and use the lever. The electric current is automatically disconnected as long as the button is in the lower position.

2 Turn the valve to the desired position.



3 To return to automatic operation, bring the lever to the position where it locks, and the button returns to the upper position. The current supply is now connected.



SUITABLE MIXING VALVES

The actuator is supplied complete with an adaptor kit for easily fitting onto an ESBE rotary mixing valve.

- Series VRG100*
 - Series VRG200*
 - Series VRB100*
 - Series MG
 - Series G
 - Series F ≤ DN50
 - Series BIV
 - Series H and HG
- *Separate adaptor kit is required, see below

LINKAGE KITS

Required adaptor kits for easily fitting onto an ESBE rotary mixing valve is available in two different styles. Adaptor kit designed for ESBE mixing valve series MG, G, F, BIV, H, HG is supplied with each actuator. Adaptor kits for ESBE mixing valve series VRG and VRB can be ordered separately.

Art. No.

1605 13 00 (= supplied with actuator)

_____ ESBE valve series MG, G, F, BIV, H, HG

1605 33 00 _____ ESBE valve series VRG, VRB

Adaptor kits for other mixing valves and valves built-into boilers are available as follows:

Art. No.

1605 16 00 _____ Centra ZR, DR, DRU

1605 17 00 _____ Centra Kompakt DRK/ZRK

1605 19 00 _____ CTC, linear movement

1605 13 00 _____ Sauter MH32...H42...

1605 25 00 _____ Siemens VBG31, VBI31, VBF21, VCI31

1605 14 00 _____ TA-VTR, TA-STM

1605 26 00 _____ TAC-TRV

1605 15 00 _____ Viessmann (all nominal diameters)

1605 18 00 _____ WITA

1605 20–24 00 Various adaptor kits for built-in mixing valves

TECHNICAL DATA

Ambient temperature: _____ max. +55°C

_____ min. -15°C

Power consumption: _____ 24V AC/DC, 5 VA

Enclosure rating: _____ IP 54

Protection class: _____ II

Torque: _____ See table

Weight: _____ 0.8 kg

ACTUATOR SERIES 90 PROPORTIONAL

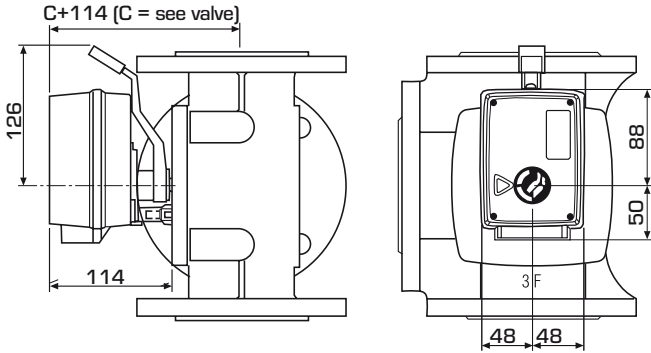

Installation dimensions for Actuator Series 90 with ESBE series MG, G, F, T/TM, H/HG and BIV mixing valves

ACTUATOR SERIES 90, PROPORTIONAL 24 VAC

Art. No.	Reference	Voltage	Running time 90° [s]	Torque [Nm]	Control signal*	Remark
1255 03 00	91P	24 VAC/24 VDC	15/30	4	0-10 V, 2-10 V, 0-20 mA, 4-20 mA	Operating range 90°
1255 01 00	92P	24 VAC/24VDC	60/90/120	15	0-10 V, 2-10 V, 0-20 mA, 4-20 mA	Operating range 90°
1255 02 00	92P2	24 VAC/24VDC	120/180/240	15	0-10 V, 2-10 V, 0-20 mA, 4-20 mA	Operating range 180°
1255 04 00	92P4	24 VAC/24VDC	120	15	0-10 V, 2-10 V, 0-20 mA, 4-20 mA	Operating range 355°

WIRING

The actuator should be preceded by a multi-pole contact breaker in the fixed installation.

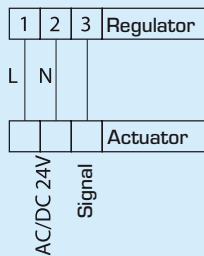

Actuator, Art. No.
1255 01 00, 1255 02 00,
1255 03 00, 1255 04 00